

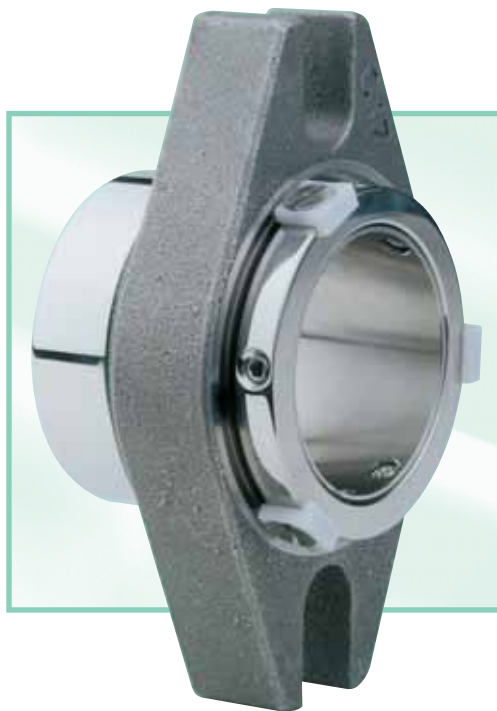

ENVIRONMENTAL TECHNOLOGY

CONVERTOR II™ Cartridge Mechanical Seal



- **BALANCED SEAL FACES**
- **EASY TO INSTALL**
- **MODERN USER-FRIENDLY DESIGN**
- **EXCELLENT GENERAL SERVICE SEAL**

WHY USE PACKING OR TWO PART SEAL AND STATIONARY DESIGNS THAT DAMAGE THE PUMP SHAFT AND SLEEVE?

FOR ENERGY SAVING, NO SHAFT DAMAGE (FRETTING), EASE OF INSTALLATION AND VALUE FOR MONEY, CONVERT TO A CONVERTOR II™.

CONVERTOR II™ - technical information

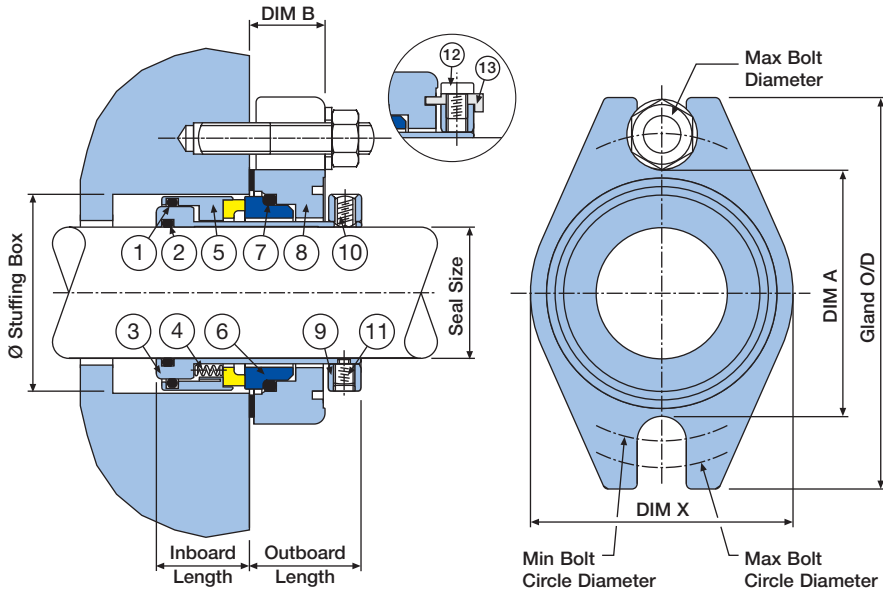

Item	Description	Material
1	Rotary O Ring	Viton® / EPR* / Aflas®* / Kalrez®*
2	Sleeve O Ring	Viton® / EPR* / Aflas®* / Kalrez®*
3	Sleeve	316L Stainless Steel
4	Springs	Alloy 276
5	Rotary Face	316L SS - Carbon / TC* / SiC*
6	Stationary Face	†Ceramic / 316L SS - CrOx** / TC / SiC
7	Stationary O Ring	Viton® / EPR* / Aflas®* / Kalrez®*
8	Gland	316 Stainless Steel
9	Clamp Ring	316L Stainless Steel
10	Drive Screws	Stainless Steel
11	Anti-Tamper Screws	Stainless Steel
12	Clip Screws	Stainless Steel
13	Setting Clips	Hard Plastic

*Available to order only.

**This material is not available from 0.000 to 2.125 (53mm).

†Not available in all sizes. Contact AESSEAL® for more information.

CONVERTOR II™ - Imperial Dimensional Information (inches)

ISSUE C

SEAL SIZE Imperial	Gland O/D	DIM A	DIM B	DIM X	Stuffing Box		Bolt Circle Dia		Max Bolt Dia	Seal Length		Sleeve O Ring	Rotary O Ring	Stationary O Ring
					Min	Max	Min	Max		Inboard	Outboard			
					1.000	4.000	2.187	0.812		2.208	1.625			
1.125	4.125	2.312	0.812	2.333	1.750	2.000	2.875	3.625	1/2	1.125	1.250	122	127	221
1.250	4.250	2.437	0.812	2.458	1.875	2.125	3.000	3.750	1/2	1.125	1.250	124	129	223
1.375	4.250	2.625	0.812	2.645	2.000	2.250	3.187	3.750	1/2	1.125	1.250	126	131	224
1.500	4.500	2.812	0.875	2.833	2.250	2.500	3.375	4.000	1/2	1.125	1.312	128	136	226
1.625	4.750	2.937	0.875	2.958	2.375	2.625	3.500	4.250	1/2	1.125	1.312	130	138	227
1.750	5.000	3.062	0.937	3.083	2.500	2.750	3.625	4.500	1/2	1.187	1.375	132	140	228
1.875	5.250	3.187	0.937	3.207	2.625	2.875	3.750	4.750	1/2	1.187	1.375	134	142	229
2.000	5.500	3.312	1.000	3.333	2.750	3.000	4.000	4.875	5/8	1.187	1.437	136	144	230
2.125	5.750	3.437	1.000	3.458	2.875	3.125	4.125	5.125	5/8	1.187	1.437	138	146	231
2.250	6.000	3.562	1.000	3.583	3.000	3.375	4.562	5.500	3/4	1.187	1.437	140	148	232
2.375	6.500	3.750	1.000	3.895	3.125	3.375	4.562	5.750	3/4	1.187	1.437	142	150	233
2.500	7.000	4.375	1.000	4.770	3.375	4.000	5.187	6.250	3/4	1.125	1.625	230	234	234
2.625	7.000	4.375	1.000	4.770	3.500	4.000	5.187	6.250	3/4	1.125	1.625	231	235	235
2.750	7.000	4.375	1.000	4.770	3.625	4.000	5.187	6.250	3/4	1.125	1.625	232	236	236
2.875	7.500	4.937	1.250	5.145	3.750	4.500	5.750	6.750	3/4	1.187	2.000	233	237	237
3.000	7.500	4.937	1.250	5.145	3.875	4.500	5.750	6.750	3/4	1.187	2.000	234	238	238
3.125	7.500	4.937	1.250	5.145	4.000	4.500	5.750	6.750	3/4	1.187	2.000	235	239	239
3.250	8.000	5.312	1.250	5.520	4.125	4.875	6.125	7.250	3/4	1.187	2.000	236	240	240
3.375	8.000	5.312	1.250	5.520	4.250	4.875	6.125	7.250	3/4	1.187	2.000	237	241	241
3.500	8.000	5.312	1.250	5.520	4.375	4.875	6.125	7.250	3/4	1.187	2.000	238	242	242
3.625	8.500	5.687	1.250	5.895	4.500	5.250	6.500	7.750	3/4	1.187	2.000	239	243	243
3.750	8.500	5.687	1.250	5.895	4.625	5.250	6.500	7.750	3/4	1.187	2.000	240	244	244
3.875	8.500	5.687	1.250	5.895	4.750	5.250	6.500	7.750	3/4	1.187	2.000	241	245	245
4.000	9.000	6.062	1.250	6.145	4.875	5.500	6.875	8.250	3/4	1.187	2.000	242	246	246

"Factory repair program is available"

CONVERTOR II™ - Metric Dimensional Information (mm)

ISSUE C

SEAL SIZE Metric	Gland O/D	DIM A	DIM B	DIM X	Stuffing Box		Bolt Circle Dia		Max Bolt Dia	Seal Length		Sleeve O Ring	Rotary O Ring	Stationary O Ring
					Min	Max	Min	Max		Inboard	Outboard			
					24	101.6	55.6	20.7		56.1	40.0			
25	101.6	55.6	20.7	56.1	41.0	48.0	69.9	88.9	12	28.6	31.8	120	125	219
28	104.8	58.8	20.7	59.3	44.0	50.0	73.1	92.1	12	28.6	31.8	122	127	221
30	108.0	61.9	20.7	62.4	46.0	54.0	76.2	95.3	12	28.6	31.8	123	128	222
32	108.0	61.9	20.7	62.4	48.0	54.0	76.2	95.3	12	28.6	31.8	124	129	223
33	108.0	61.9	20.7	62.4	49.0	55.0	76.2	95.3	12	28.6	31.8	125	130	223
35	108.0	66.7	20.7	67.2	51.0	59.0	81.0	95.3	12	28.6	31.8	126	131	224
38	114.3	71.5	22.3	72.0	57.2	62.0	85.8	101.6	12	28.6	33.4	128	136	226
40	114.3	71.5	22.3	72.0	58.0	64.0	85.8	101.6	12	28.6	33.4	129	136	226
43	120.7	74.6	22.3	75.1	61.0	67.0	88.9	108.0	12	28.6	33.4	131	138	227
45	127.0	77.8	23.8	78.3	63.5	69.0	92.1	114.3	12	30.2	35.0	132	140	228
48	133.4	81.0	23.8	81.5	66.7	72.0	95.3	120.7	12	30.2	35.0	134	142	229
50	133.4	81.0	23.8	81.5	68.0	74.0	95.3	120.7	12	30.2	35.0	136	142	229
53	139.7	84.2	25.4	84.7	71.0	77.0	101.6	123.9	16	30.2	36.5	138	144	230
55	146.1	87.3	25.4	87.8	74.0	79.0	104.8	130.2	16	30.2	36.5	139	146	231
58	165.1	95.3	25.4	98.9	79.4	85.7	115.9	146.0	20	30.2	36.5	140	148	232
60	165.1	95.3	25.4	98.9	79.4	85.7	115.9	146.0	20	30.2	36.5	142	150	233
63	177.8	111.2	25.4	121.2	85.8	101.6	131.8	158.7	20	28.6	41.2	230	234	234
65	177.8	111.2	25.4	121.2	88.9	101.6	131.8	158.7	20	28.6	41.2	231	235	235
68	177.8	111.2	25.4	121.2	92.1	101.6	131.8	158.7	20	28.6	41.2	232	236	236
70	177.8	111.2	25.4	121.2	92.1	101.6	131.8	158.7	20	28.6	41.2	232	236	236
75	190.5	125.4	31.7	130.7	98.5	114.3	146.1	171.4	20	30.2	50.8	234	238	238
80	190.5	125.4	31.7	130.7	101.6	114.3	146.1	171.4	20	30.2	50.8	235	239	239
85	203.2	135.0	31.7	140.2	108.0	123.8	155.6	184.1	20	30.2	50.8	237	241	241
90	215.9	144.5	31.7	149.7	114.3	133.3	165.1	196.8	20	30.2	50.8	239	243	243
95	215.9	144.5	31.7	149.7	117.5	133.3	165.1	196.8	20	30.2	50.8	240	244	244
100	228.6	154.0	31.7	156.1	123.9	139.7	174.7	209.5	20	30.2	50.8	242	246	246

"Replacement seal kits are available"

THIS DOCUMENT IS DESIGNED TO PROVIDE DIMENSIONAL INFORMATION AND AN INDICATION OF AVAILABILITY. FOR FURTHER INFORMATION AND SAFE OPERATING LIMITS CONTACT OUR TECHNICAL SPECIALISTS AT THE LOCATIONS BELOW.



USE DOUBLE MECHANICAL SEALS WITH HAZARDOUS PRODUCTS. ALWAYS TAKE SAFETY PRECAUTIONS:

- GUARD YOUR EQUIPMENT
- WEAR PROTECTIVE CLOTHING



UK Sales & Technical advice:

AESSEAL plc
Mill Close
Templeborough
Rotherham
S60 1BZ
United Kingdom



INVESTOR IN PEOPLE

Telephone: +44 (0) 1709 369966
Fax: +44 (0) 1709 720788
E-mail: seals@aes seal.com
Internet: http://www.aes seal.com

Distributed by:

Our Purpose: *'To give our customers such exceptional service that they need never consider alternative sources of supply.'*

USA Sales & Technical advice:

AESSEAL Inc.
355 Dunavant Drive
Rockford,
TN. 37853
USA

Telephone: +1 865 531 0192
Fax: +1 865 531 0571
E-mail: usa@aes seal.com